

Inter-Turn Fault Detection of PMSM Based on Fuzzy Logic and Discrete Wavelet Transform Using Unsupervised Clustering

Vahid Khodashenas Limouni^{✉1,2}, S.Asghar Gholamian³, Mehran Taghipour Gorjikotaie⁴

1) Department of Electrical Engineering, Ali Abad Katoul Branch, Islamic Azad University, Ali Abad Katoul, Iran

2) Young Researchers and Elite Club, Ali Abad Katoul Branch, Islamic Azad University, Ali abad Katoul, Iran

3) Faculty of Electrical and Computer Engineering, Babol University of Technology, Babol, Iran

4) Faculty of Electrical Engineering, University of Birjand, Birjand, Iran

vahid.khodashenas@yahoo.com; gholamian@nit.ac.ir; mtaghipour@birjand.ac.ir

Received: 2015/08/14; Accepted: 2015/11/23

Abstract

The idea of this paper is designing an automatic fault detection system based on fuzzy logic, therefore two signals of PMSM in fault condition are analyzed for inter turn fault detection: current and torque. In this fault type there is some distortion in these signals, but it is not good enough to detecting with fuzzy logic solely, so with combination of wavelet transform and FCM a new method for fault detection is introduced. In this method one detail signal of wavelet transform is chosen and then with FCM it is divided into 6 clusters, these clusters describe the situation of signal truly. Using FCM has two advantages: first in some clusters there had been fault therefore fault was detected, and second it is used for fuzzy logic system to deciding amount and intensity of fault of PMSM. By applying combination of wavelet transform and FCM, designing of fuzzy logic has been more effective, the MFs are directly come from output of FCM, therefore fuzzy logic system have more accurate answer. The output of fuzzy logic that is showed in surface view is based on tree situation that is defined in output MF, and describes whole conditions of PMSM and shows the amount of inter turn fault.

Keywords: Fault Detection, FCM, Turn to Turn Fault, PMSM, Wavelet Transform

1. Introduction

Nowadays PMSMs are very suitable for industrial applications because of its high efficiency, compactness, low weight and high torque. So it is more and more in use and running in many systems, therefore fault detection of it seems necessary to protecting the system and wasting cast and time [1-3].

In this field the authors in [1] have been proposed a fault tolerant model to realize the electric fault of PMSM. It mentioned that when short circuit happen it becomes hard to find the fault so it used wavelet transform to find the effects of it and extracting the features from phase current. This paper showed some points in the wavelet transform that fault happening are obvious on it. So wavelet transform seems so efficient. Also turn fault is obvious in back electromotor force (EMF) and impedance unbalance element, which effects on torque in bad ripples and heating up the motor [2]. For

example ref [2] modeled the motor in the fault and normal condition and negative sequence components of current is achieved, and the changes of it between two models showed the fault. In some papers like [3] PMSM faults are detected based on sliding mode observer, it is avoiding the chattering phenomenon. For this application at first PMSM is modeled on MATLAB with space state model and then defined sliding equations and then designed the observer for estimating fault, in this method the rotor angular position is tracked and electromagnetic torque is linearized the sliding mode variable shows the error between estimation and real model, so it detected the fault [3]. Ref [4] consist on using back electromotor force (EMF) estimator, it introduced an open loop estimator that electro thermal model of machine is inside of it. Detecting the fault is based on difference between reference EMF and estimated EMF. This method can detect fault for a vast speed range and in blurring effects of harmonics too. The current of stator can be used to detect the fault too, therefore the current is analyzed with Fourier transform and wavelet transform in [5], it analyzed the first, 5th, 7th and 11th harmonics of current in high motor speed, and showed that these harmonics completely detect the fault. Ref [6] proposed analyzing 2nd harmonic component of the voltage in the d-q frame for inter turn fault detection of PMSM, by comparing the amplitude of these harmonic with healthy one. The idea in some papers is detecting fault of PMSM without circuit model, so a dynamic model is presented in fault condition, and then all of the parameters was calculated, and with comparing with normal condition the fault can be detected. This method is faster in fault detection, and parametric study easy performed too [7]. Extracting frequencies of stator current and frequency components of noise is suitable. The noise features are effective in little inter turn fault detecting, because in this case the fault is not obvious enough in the current and its frequency [8, 9]. It is showed that feature extracting from frequency components is useful to inter turn fault detection.

In this paper stator current and torque are analyzed for detecting inter turn fault of PMSM, this parameters are not good enough for this fault detection, so some features has been extracted. Discrete wavelet transform has been used for it and for detecting and discriminating the fault a fuzzy unsupervised clustering method named fuzzy C-means (FCM) is employed, and finally for detecting motor situation and tensivity of fault automatically a fuzzy logic system has been introduced.

2. Modeling of Inter Turn Fault for PMSM

The Permanent Magnet Synchronous Motor (PMSM) is an AC synchronous motor whose field excitation is provided by permanent magnets, but has a sinusoidal Back EMF waveform. PMSMs are gaining popularity because of their superior performance, high efficiency and energy density. Their applications are on the rise in industrial motor drives, variable speed wind turbine, electric vehicle, household equipment, also they are extremely in use in: air conditioner & refrigerator compressors direct-drive washing machine, automotive electrical power steering, machining tools and traction control.

In this paper PMSM is modeled based on 3 phase equations and abc model, shown in Figure 1.

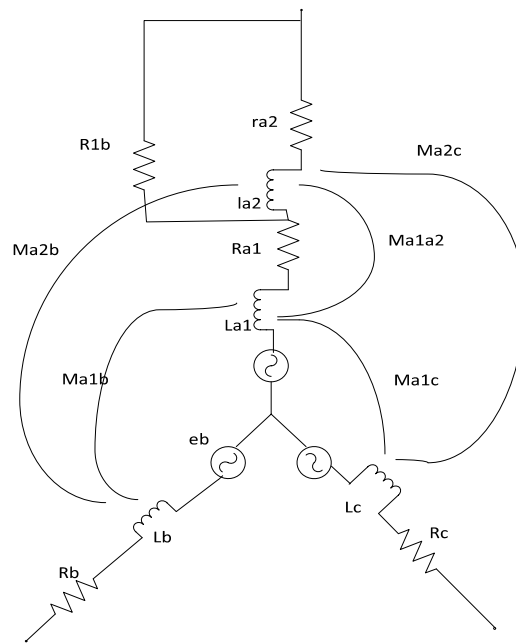

Figure 1. Model of PMSM under inter-turn fault

Short circuit is happened in phase “a” so there is some changes in inductance and resistance of that phase, this fault is simulated by a shunt resistance (Rsh) in that winding. The mutual inductance between phase changes, and there is mutual inductance between damaged part and healthy part of the winding, that is modeled by (ma1a2) in Figure 1. And also (ma1c) is mutual inductance between (La1) and (Lc), (ma1b) is mutual inductance between (La1) and (Lb), (ma2c) is mutual inductance between (La2) and (Lc) and (ma2b) is mutual inductance between (La2) and (Lb).

Suppose X is fault percent in (1):

$$x = \frac{Nf}{N} \tag{1}$$

Where N is the total number of winding's turns and Nf is the number of damaged turns.

The relation of resistance and inductance with turns' number is showed in (2):

$$R = \rho \frac{l}{A} \Rightarrow R \propto N$$

$$L = \frac{N^2}{R_m} \Rightarrow L \propto N^2 \tag{2}$$

Where, A is area of winding surface, ρ is resistivity and l is length of winding, N is the number of winding turns and Rm is magnetic reluctance of magnetic path. It is obvious from this equation that l and N have a direct relation with resistance; also, L has direct relation with square of number of winding turns; therefore inductance and resistance of damaged phase can be calculated:

$$N_a = N_b = N_c = N \tag{3}$$

$$N_{a2} = N_f \Rightarrow N_{a2} = X \times N \tag{4}$$

$$N_{a2} + N_{a1} = N_a = N \Rightarrow N_{a1} = (1-x) \times N \tag{5}$$

$$r_{a1} = X \times r_a \text{ and } r_{a2} = (1-X) \times r_a \tag{6}$$

$$\frac{L_{a2}}{L} = \frac{\frac{N_f^2}{R_m}}{\frac{N^2}{R_m}} = \frac{N_f^2}{N^2} = (1-X)^2 \Rightarrow L_{a2} = (1-x)^2 \times L \quad (7)$$

$$\frac{L_{a1}}{L} = \frac{\frac{(N-N_f)}{R_m}}{\frac{N^2}{R_m}} = \frac{(N-f)^2}{N^2} = (1-X)^2 \Rightarrow L_{a1} = (1-X)^2 \times L \quad (8)$$

$$M_{a2c} = \frac{N_c \times N_{a2}}{R_m} = \frac{N \times [X \times N]}{R_m} = X \times L \quad (9)$$

3. Wavelet Transform Analysis

Wavelet transform is a method for solving some difficult problems in engineering, mathematics and physics. In fact it is the improved version of fourier transform. Wavelet transform can show some some aspects of signal that other signal processing method miss, like beakdown points,trends and discontinuities in higher drivatives, also by using the proper mother wavelet function more details from signal can be extacted. Figure 2 shows how wavelet works.

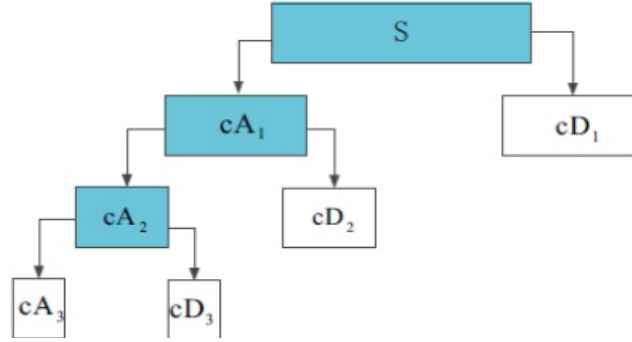

Figure 2. Wavelet decomposition scheme

Trough the Wavelet transform of a signal “s” for example, that decmpsed into two signals: “CA1” and “CD1”. CA1 is the data quantity in the signal and CD1 is the half of the raw signal “s”. CA1 contains the low frequency information and CD1 contains the high frequency information. Actually CA1 has more effective information of main signal and CD1 belongs to noise and other distortians. CA1 is decomposed with Wavelet transform again and CA2 and CD2 are obtained, CA2 decomposed again to CA3 and CD3. This process continue to reach to desired details. In the Figure 2 the decomposition process is showed.

The general definition of wavelet is contiuous wavelet transform (CWT):

$$W(a,b,x,\varphi) = |a|^{-\frac{1}{2}} \int_{-\infty}^{+\infty} x(t) \varphi^* \left(\frac{t-b}{a} \right) \partial t \quad (10)$$

Where, $\psi^*(.)$ is the basic wavelet function, a is the dilation factor and b is the translation of the origin. Although time and frequency do not appear explicitly in the transformed result, the variable $1/a$ gives the frequency scale and b, the temporal location of an event. The wavelet function can be defined as $W(a, b, x, \varphi)$, that is

energy of x of scale a at $t = b$; in the discrete wavelet transform (DWT) the translation and deletion parameters have discrete values [10].

4. Fuzzy C-Means Clustering

Clustering is one of the most widely used techniques for exploratory data analysis, with applications ranging from statistics, computer science, and biology to social sciences or psychology. In virtually every scientific field dealing with empirical data, people attempt to get a first impression on their data by trying to identify groups of “similar behavior” in their data. Data clustering is the process of dividing data elements into classes or clusters so that items in the same class are as similar as possible, and items in different classes are as dissimilar as possible. Fuzzy clustering is a process of assigning these membership levels, and then using them to assign data elements to one or more clusters.

One of the most widely used fuzzy clustering algorithms is the Fuzzy C-Means (FCM) Algorithm.

Fuzzy C-means (FCM) clustering is an unsupervised clustering method, which its general algorithm was mentioned on [11, 12]. in this algorithm all data are assigned to their categories by fuzzy memberships, let $X = \{x_i; i=1;2; \dots ; N/x_i \in R^d\}$ be a signal with N data that must be clustered in C classes, X_i is feature data; there is an iterative objective function(J^m) that must be minimized in the optimization algorithm of FCM [13]:

$$J_m = \sum_{k=1}^c \sum_{i=1}^N u_{ki}^m \|X_i - v_k\|^2 \quad (11)$$

And:

$$\begin{aligned} \sum_{k=1}^c u_{ki} &= 1 & \forall i \\ 0 \leq u_{ki} \leq 1 & & \forall k, i \\ \sum_{i=1}^N u_{ki} > 0 & & \forall k \end{aligned} \quad (12)$$

Here u_{ki} is the membership of x_i in the k th cluster, v_k is the k th class center, $k \in \{1, \dots, c\}$ is the Euclidean distance, $m > 1$ is a weighting exponent on each fuzzy membership. The parameter m controls the fuzziness of the resulting partition. The membership functions U and cluster centers V will be updated by the following expressions:

$$u_{ki} = \frac{1}{\sum_{l=1}^c \left(\frac{\|X_i - v_k\|}{\|X_i - v_l\|} \right)^{\frac{2}{m-1}}} \quad (13)$$

And:

$$v_k = \frac{\sum_{i=1}^N u_{ki}^m X_i}{\sum_{i=1}^N u_{ki}^m} \quad (14)$$

By using (13) and (14) U and V would be updated through this iterative process.

5. Fuzzy Logic Based Fault Detection

Fuzzy logic is widely used in electrical industries nowadays. The term “fuzzy” refers to the fact that the logic involved can deal with concepts that cannot be expressed as the “true” or “false” but rather as “partially true”. Although alternative approaches such as genetic algorithms and neural networks can perform just as well as fuzzy logic in many cases, fuzzy logic has the advantage that the solution to the problem can be cast in terms that human operators can understand, so that their experience can be used in the design of system. This makes it easier to mechanize tasks that are already successfully performed by humans.

Fuzzy logic was first proposed by Lotfi A. Zadeh of the University of California at Berkeley in a 1965 paper. He elaborated on his ideas in a 1973 paper that introduced the concept of “linguistic variables”, which in this article equates to a variable defined as a fuzzy set. Other research followed, with the first industrial application, a cement kiln built in Denmark, coming on line in 1975. Fuzzy systems were initially implemented in Japan. Work on fuzzy systems is also proceeding in the United State and Europe, although on a less extensive scale than in Japan [15].

The input variables in a fuzzy system are in general mapped by sets of membership functions similar to this, known as “fuzzy sets”. The process of converting a crisp input value to a fuzzy value is called “fuzzification”.

Making the decision is based on a set of rules:

- All the rules that apply are invoked, using the membership functions and truth values obtained from the inputs, to determine the result of the rule.
- This result in turn will be mapped into a membership function and truth value controlling the output variable.
- These results are combined to give a specific (“crisp”) answer, the actual brake pressure, a procedure known as “defuzzification”.

This combination of fuzzy operations and rule-based ”inference” describes a “fuzzy expert system”.

In the Figure 3 the fuzzy system is showed.

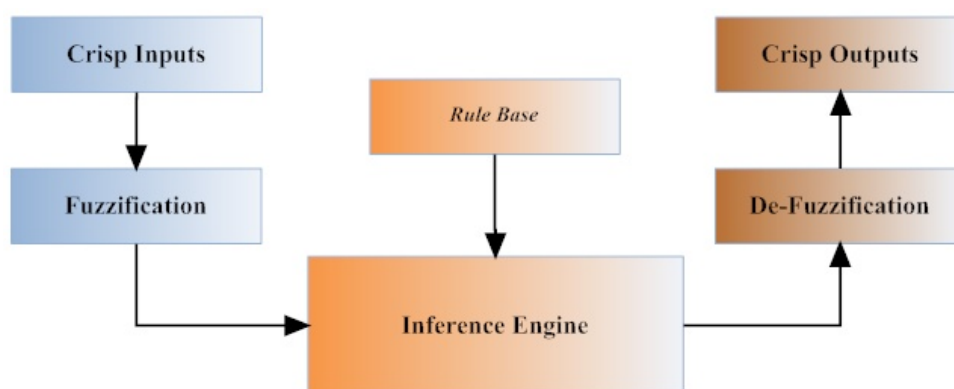

Figure 3. Fuzzy system

In the fuzzy logic multivalued logic relates to objects with a degree of membership, in this method linguistic variable are used instead of numbers, it has some advantages like flexibility and tolerance to inexact data. In fuzzy logic the rule base defined based on experience of user [14]. In this paper the Gaussian membership functions is used which

had reasonable results output and the fuzzy rules was defined based on our knowledge from fault detection and motor condition.

6. Simulation Results And Discussions

In this paper PMSM is simulated with Matlab 7.6.0324 R2008a and with windows 7-64 bit, 2.6 GH CPU and 4 Gb RAM. Table 1 shows the studied PMSM parameters.

Table 1. studied PMSM parameters

parameters	values
Source voltage (line-RMS)	560 V
Inductance of each healthy winding (L)	1.182 (mH)
Mutual inductance between two healthy winding (M)	0.136 (mH)
Resistance of each healthy winding (r)	0.016 (Ω)
Rated speed	2500 (rpm)

The PMSM is simulated in 35% fault with MATLAB. First the current of stator is simulated under the inter turn stator winding fault. The current is more available signal in PMSM therefore it is chosen first of analyzing in this paper. As can be seen in Figure 4 there is some noises in the fault section that is occurred in $t=2s$.

The second parameter that is analyzed is torque, because the inter turn fault effects on it like the effects in current as some noises. The Figure 5 shows the torque of motor that fault is occurred in $t=2s$.

It is obvious that detection of fault is so difficult directly from these two signals. So discrete wavelet transform is used to denoising, feature extraction and better detection of fault and after it, fuzzy C-means clustering (FCM) is used to automatic fault diagnosis.

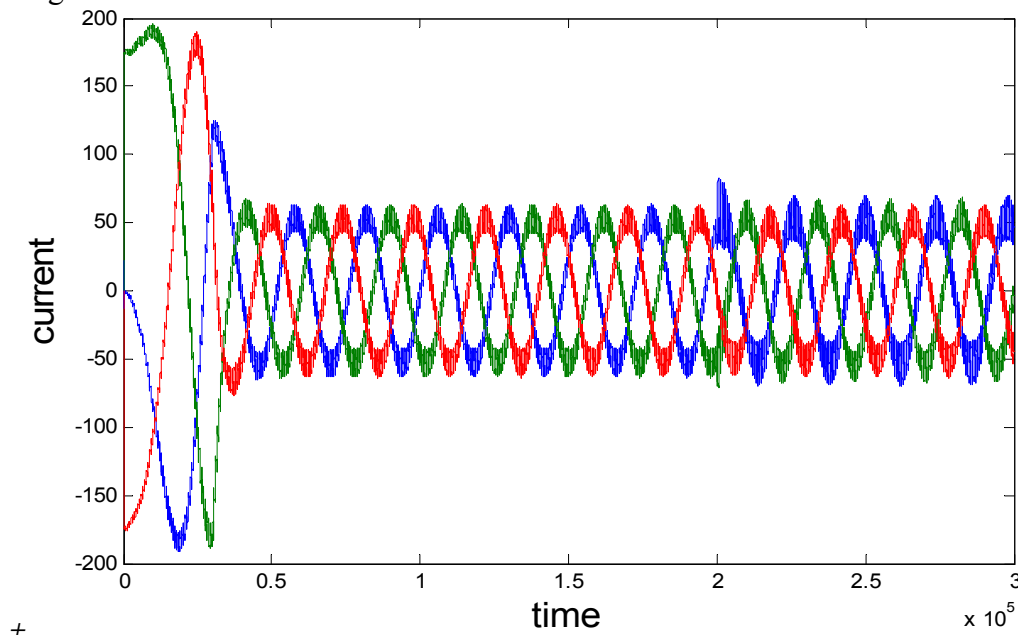

Figure 4. Current of PMSM under 35% fault

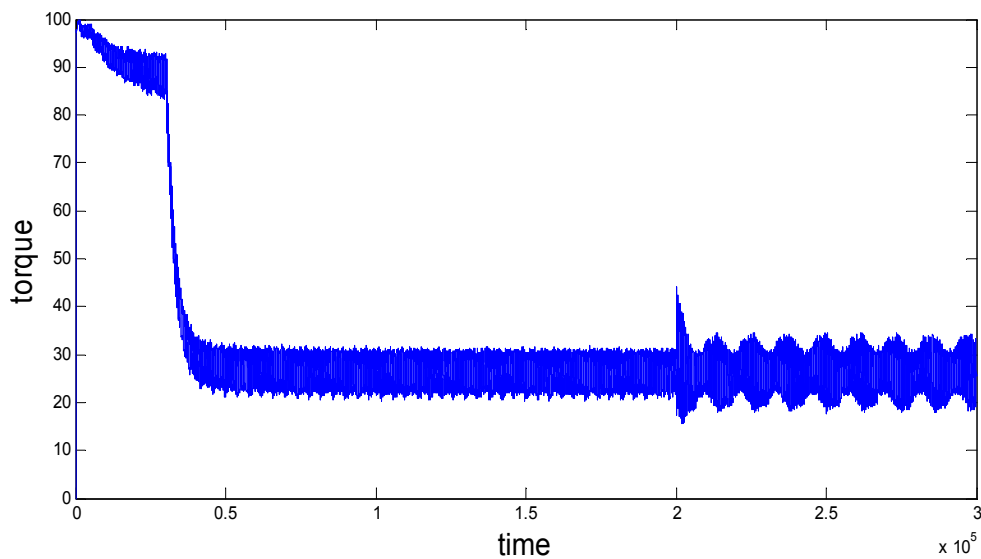

Figure 5. Torque of PMSM under 35% fault

In Figure 6 current is showed after DWT and FCM.

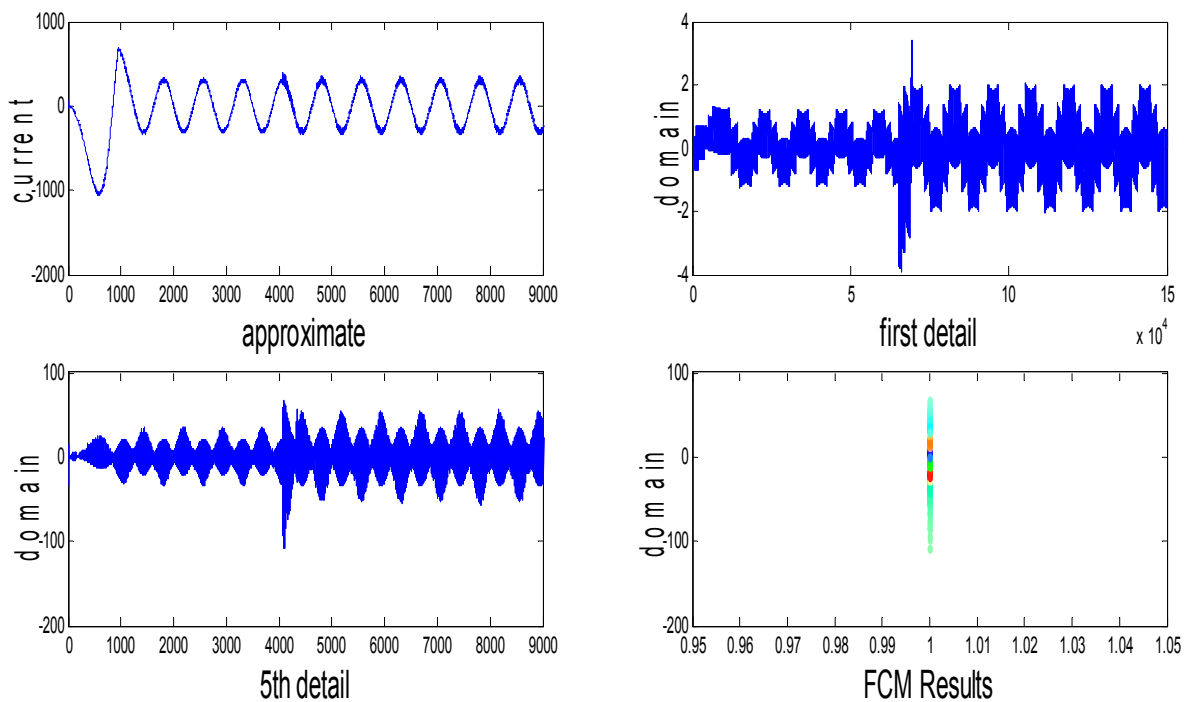

Figure 6. Wavelet and FCM of current

The first window is approximation of main signal of current and second and third windows are 1st and 5th details of the signal that is taken from DWT. The *Haar* wavelet is implemented. The 4th window is the most important of them that shows output of the FCM of main signal, this window clearly shows that fault is discriminated automatically. There is 6 clusters in FCM, this clusters are chosen tentative and after testing 2, 3, 4 and 5 clusters there has been seen that was a good clustering for detecting and discriminating fault with wavelet and FCM.

In this 6 clusters in FCM, 2 of them are in fault and the other 4 are healthy. This is showed with different colors. The blue color is the border of fault from up and the yellow and green are from down too. The other data are in healthy condition. FCM discriminated all of the data truly. Figure 7 is showed the torque signal.

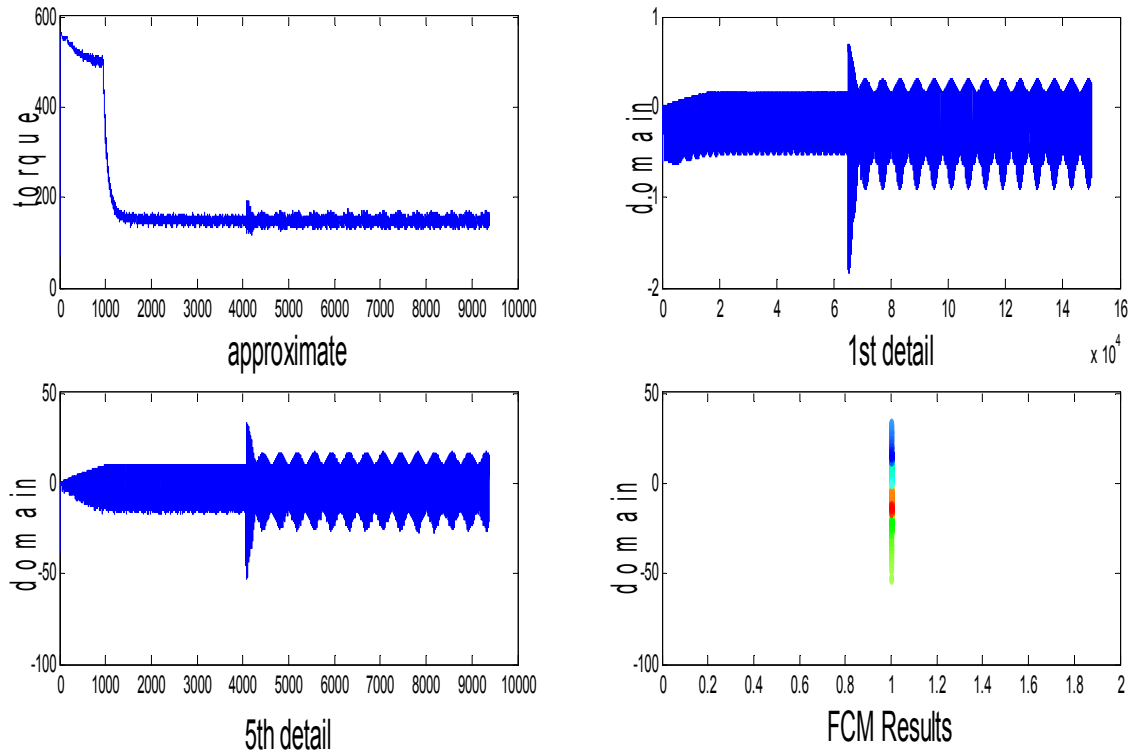

Figure 7. Wavelet and FCM of torque

As it mentioned for current, the first window is approximate of main signal and second and third windows are 1st and 5nd details of it, and last window is FCM of DWT of torque. As is obvious the dark blue is the border of fault and healthy from above and the green is from down.

The main purpose of this paper is intelligent fault detection, and this is here, with fuzzy logic provides an intelligent system and also showed amount of fault. The input of fuzzy logic system is from output of FCM. With the two inputs of current and torque the fault detection system is designed. The Figure 8 shows the membership functions of input from current.

This is directly driven from output of FCM, it can be seen that it helped to reach to MFs truly. There were 6 clusters so there are 6 membership functions for input. The MFs are Gaussian because FCM has fuzzy nature itself, so it can help to a more correct answer.

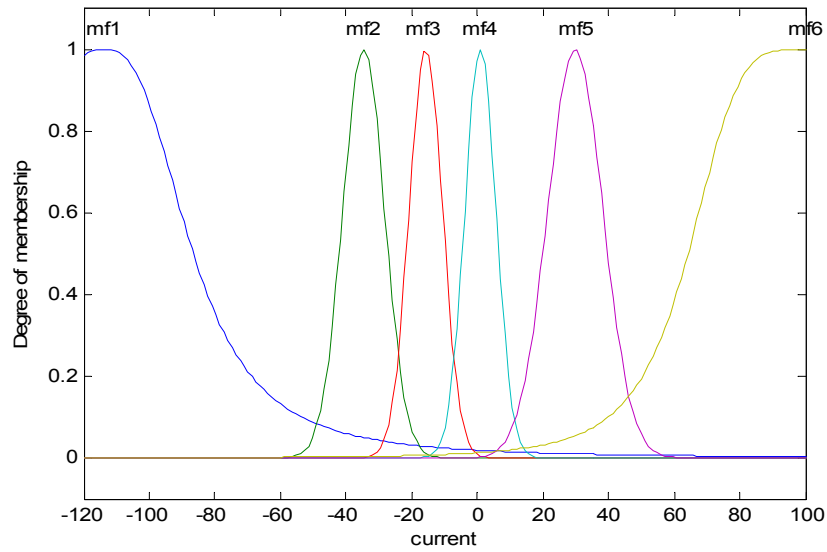

Figure 8. Membership functions of 1st input =current

The Figure 9 shows input MFs of torque. These MFs are like before. There were 6 clusters so it has 6 MFs.

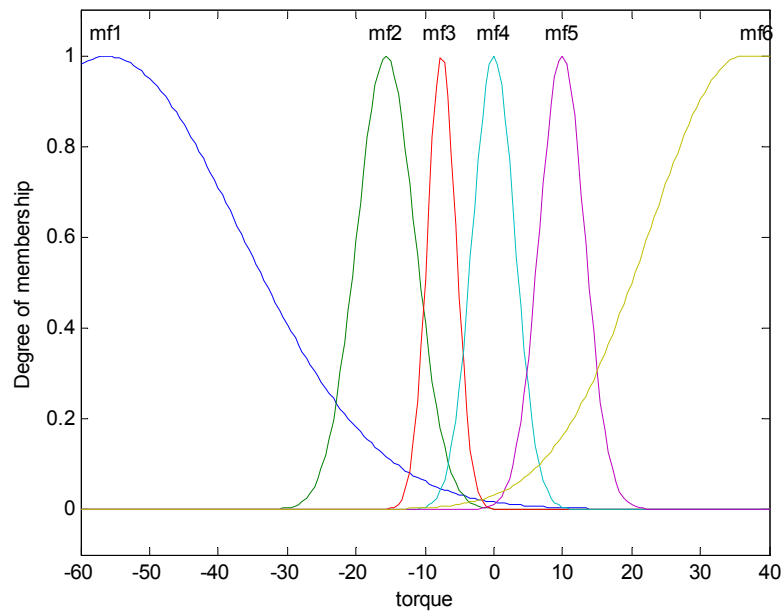

Figure 9. Membership functions of second input =torque

Output MFs of system are designed as it is in Figure 10.

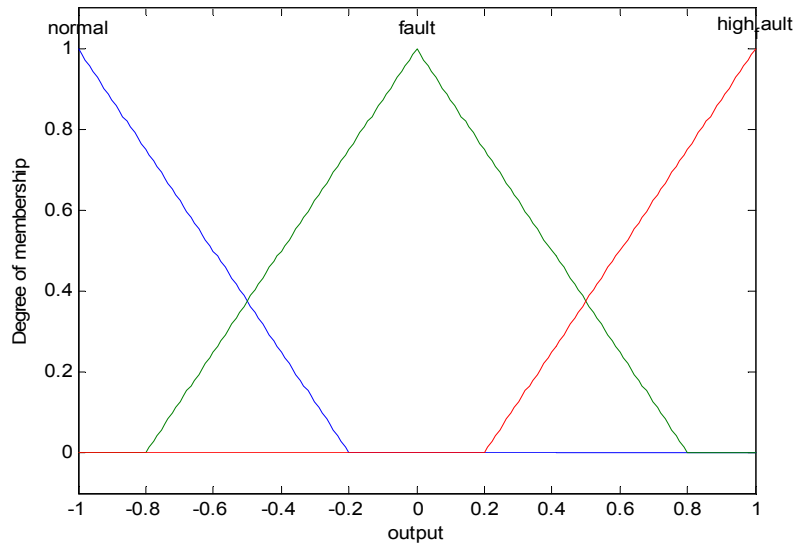

Figure 10. Output MFs

There are 3 stages for output: normal, fault and high fault. In this fuzzy system, the output range between -1 to about -0.5 means the motor is normal, and -0.5 to 0.5 means fault and more than 0.5 means motor has high fault. The fuzzy system is showed in Figure 11.

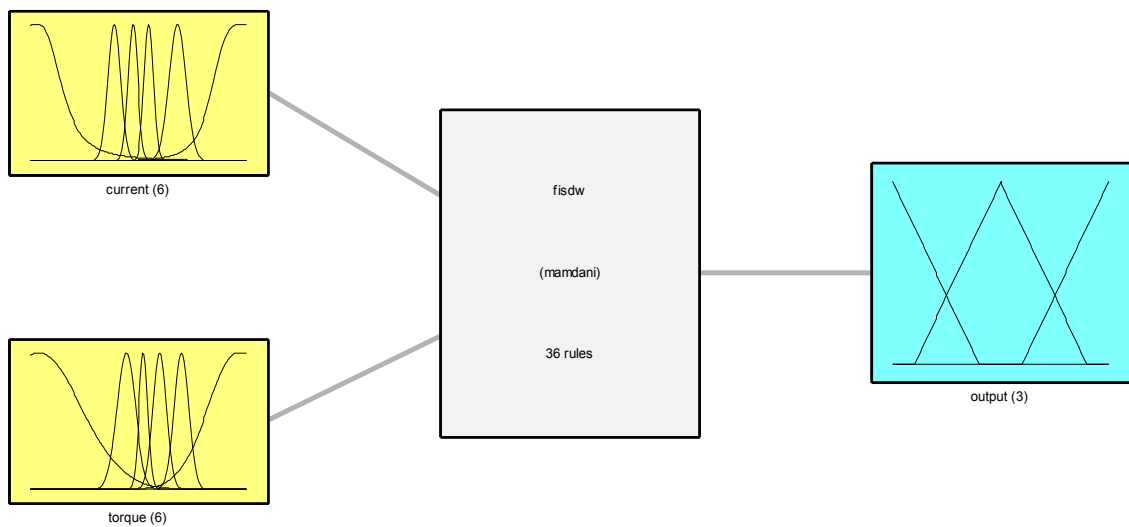

Figure 11. Fuzzy logic system

There are 2 inputs and 1 output.

There is 6 condition for 1st input because of 6 cluster of FCM and 6 for 2nd input, and 3 for output, therefore it is written 36 rules for the fuzzy logic system. The rules are written based on our experience and the PMSM condition. In Table 2 some rules are showed.

Table 2. rules of fuzzy logic

IF	Current is MF1	AND	Torque is MF1	THEN	Output is high fault
IF	Current is MF2	AND	Torque is MF1	THEN	Output is fault
IF	Current is MF3	AND	Torque is MF1	THEN	Output is fault
IF	Current is MF4	AND	Torque is MF1	THEN	Output is fault
IF	Current is MF5	AND	Torque is MF1	THEN	Output is fault
IF	Current is MF6	AND	Torque is MF1	THEN	Output is high fault
IF	Current is MF1	AND	Torque is MF2	THEN	Output is high fault
IF	Current is MF2	AND	Torque is MF2	THEN	Output is normal
IF	Current is MF3	AND	Torque is MF2	THEN	Output is normal
IF	Current is MF4	AND	Torque is MF2	THEN	Output is normal
IF	Current is MF5	AND	Torque is MF2	THEN	Output is normal
IF	Current is MF6	AND	Torque is MF2	THEN	Output is fault
IF	Current is MF1	AND	Torque is MF3	THEN	Output is fault
IF	Current is MF2	AND	Torque is MF3	THEN	Output is normal
IF	Current is MF3	AND	Torque is MF3	THEN	Output is normal
IF	Current is MF4	AND	Torque is MF3	THEN	Output is normal
IF	Current is MF5	AND	Torque is MF3	THEN	Output is normal
IF	Current is MF6	AND	Torque is MF3	THEN	Output is fault
IF	Current is MF1	AND	Torque is MF4	THEN	Output is fault
IF	Current is MF2	AND	Torque is MF4	THEN	Output is normal
IF	Current is MF3	AND	Torque is MF4	THEN	Output is normal
IF	Current is MF4	AND	Torque is MF4	THEN	Output is normal
IF	Current is MF5	AND	Torque is MF4	THEN	Output is normal
IF	Current is MF6	AND	Torque is MF4	THEN	Output is fault
IF	Current is MF1	AND	Torque is MF5	THEN	Output is fault
IF	Current is MF2	AND	Torque is MF5	THEN	Output is normal
IF	Current is MF3	AND	Torque is MF5	THEN	Output is normal
IF	Current is MF4	AND	Torque is MF5	THEN	Output is normal
IF	Current is MF5	AND	Torque is MF5	THEN	Output is normal
IF	Current is MF6	AND	Torque is MF5	THEN	Output is fault
IF	Current is MF1	AND	Torque is MF6	THEN	Output is high fault
IF	Current is MF2	AND	Torque is MF6	THEN	Output is fault
IF	Current is MF3	AND	Torque is MF6	THEN	Output is fault
IF	Current is MF4	AND	Torque is MF6	THEN	Output is fault
IF	Current is MF5	AND	Torque is MF6	THEN	Output is fault
IF	Current is MF6	AND	Torque is MF6	THEN	Output is high fault

And finally surface of output of fuzzy logic system that shows whole situations available is showed in Figure 12. In this Figure the blue zone shows that PMSM is in normal situation and the green shows there is fault in it, and the red color shows that motor is bad damaged. Actually this Figure describes the output of fuzzy logic system designed, based on some qualitative relations.

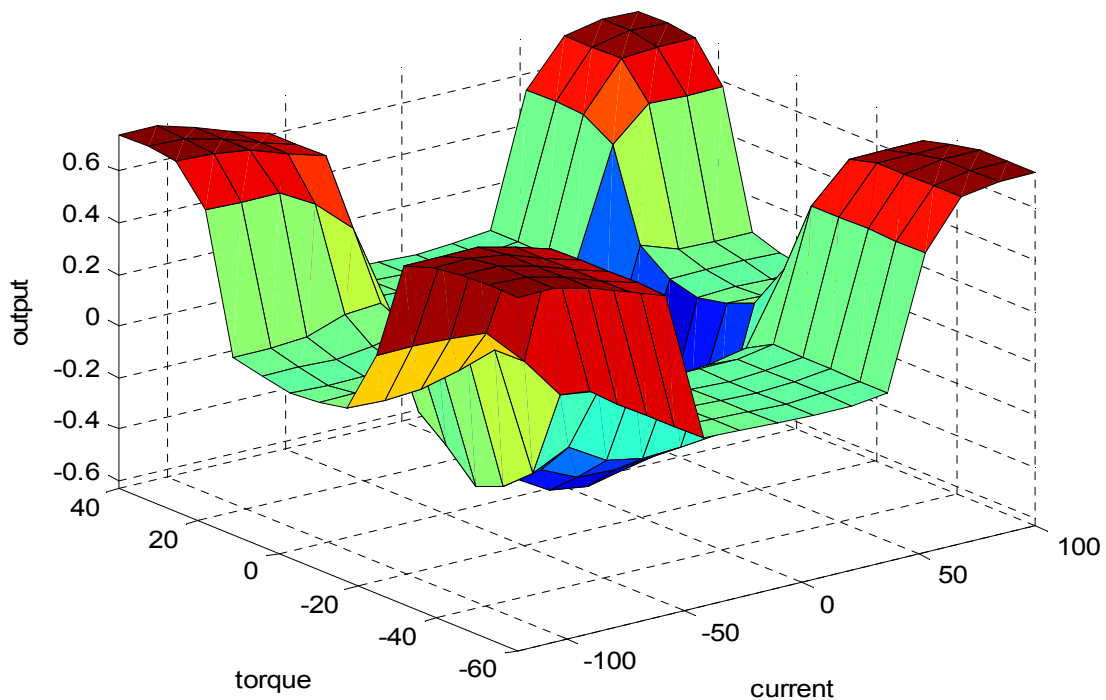
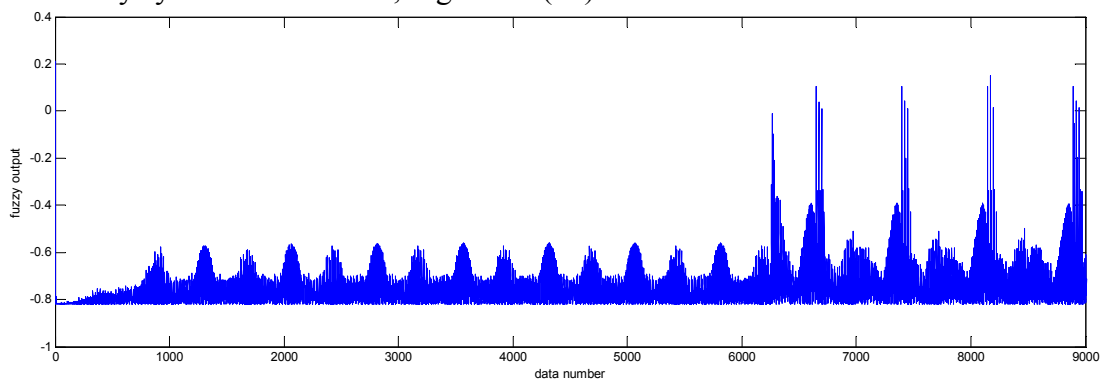

Figure 12. Surface view

The fuzzy system is tested too; Figureure (13) has been showed this.



Figureure13. output of fuzzy system for 30% fault

This fuzzy system is tested for a 30% fault PMSM that has two part: healthy and faulty. The healthy part is less than -0.5, according to fuzzy output MFs, the fuzzy inference system works absolutely true. The faulty part is about 0.15 that shows fault condition correctly.

This paper introduced a new method for inter turn fault detection of PMSM in two parts:

Part 1 is detecting fault by combination of wavelet transform and FCM, the idea is detecting fault using unsupervised fuzzy clustering, so after calculating wavelet transform of input signals FCM implemented and detected the fault in its some clusters correctly. This is a new method that has both fuzzy and wavelet advantages, like robustness in fuzzy and denoising in wavelet.

In part 2 a fuzzy logic system is designed with a new formula. All of the fuzzy logic systems are based on experience and knowledge of user from the system, in this paper the input MFs are come from output of combination of wavelet and FCM, so there is the

minimum error around output. In this paper a new approach of fault detection is introduced by improving effectiveness and reliability of fuzzy logic system.

7. Conclusion

Permanent magnet synchronous machines (PMSM) are common in use in modern industries; it seems that detecting its fault is very important. The electrical faults in PMSMs are so harmful, one of the most important electrical faults is inter turn stator winding fault. This paper introduced an intelligent fault detection system based on fuzzy logic theory. The model of PMSM is simulated in MATLAB and the current signal of stator in fault condition is extracted and analyzed then with calculating wavelet transform of this signal the features are extracted, and after it with a fuzzy unsupervised clustering method (FCM) the fault is discriminated and detected. For better checking and evaluation of fault the torque signal is analyzing too. Finally with this two signals as inputs the fault detection system is designed based on fuzzy logic, this system has been alarmed the fault and has been showed the intensity of fault in PMSM.

Wavelet transform that is implemented in this paper have some remarkable advantages:

The main advantage is localization in both time and frequency domain. The other is that it is computationally fast, so there is frugality in time and software. Also wavelet transform separated the fine details using Haar wavelet and it has better analyze than the other signal processing techniques like Fourier transform in fault detection.

The other innovation of this paper is using output of fuzzy clustering for fuzzy system. In all fuzzy systems the inputs are defined by experience of user and there might be some error, but in this paper the input MFs are directly from FCM, this automatic MF designing is more efficient.

Fuzzy logic system implemented is the most important distinction of this paper that has flexibility and tolerance to inexact data, so has more efficiency in noisy condition than the other fault detection systems.

References

- [1] Z.Chen, R.Qi, H.Lin, "inter-turn short circuit fault diagnosis for PMSM based on complex gauss wavelet" International Conference on Industrial Electronics, 2007.
- [2] B-G.Gu, J. Choi, and I-S Jung, "Dynamic PMSM Motor Model with Turn Short Fault for Wind Power Generation, "International Conference on Renewable Energies and Power Quality, 2013.
- [3] Y.Huangfu, W. Liu, R.Ma, "Permanent magnet synchronous motor fault detection and isolation using second order sliding mode observer," 3rd IEEE Conference on Industrial Electronics and Applications,2008.
- [4] A.Sarikhani, O.A. Mohammed, "Inter-turn Fault Detection in PM Synchronous Machines by Physics-based EMF Estimation, "IEEE Transactions on Industrial Electronics, 2013.
- [5] J. Rosero, J. L. Romeral, J. Cusido, J. A. Ortega, A. Garcia, " Fault Detection of Eccentricity and Bearing Damage in a PMSM by means of Wavelet Transforms,"Applied Power Electronics Conference and Exposition Twenty-Third Annual IEEE,2008.
- [6] T.Boileau, N.Leboeuf, B.Nahid-Mobarakeh, F. Meibody-Tabar, "Synchronous Demodulation of Control Voltages for Stator Interturn Fault Detection in PMSM," IEEE Transactions on Power Electronics,2013.

- [7] N.Leboeuf, T.Boileau, B. Nahid-Mobarakeh, N.Takorabet, F.Meibody-Tabar, and G.Clerc, "Estimating Permanent-Magnet Motor Parameters Under Inter-Turn Fault Conditions," IEEE Transactions on Magnetics, 2012.
- [8] N. Leboeuf, T. Boileau, B. Nahid-Mobarakeh, , N. Takorabet, F. Meibody-Tabar, G. Clerc, "Effects of Imperfect Manufacturing Process on Electromagnetic Performances and Onlin Inter-Turn Fault Detection in PMSMs," IEEE transactions on Industrial electronics,2015.
- [9] Y.h.Liang, "Diagnosis of Inter-Turn Short-Circuit Stator Winding Fault in PMSM Based on Stator Current and Noise, " IEEE International Conference on Industrial Technology , 2014.
- [10] J Rosero, J.Romeral, ,L.Cusino , "fault detection of eccentricity and bearing damage on PMSM by means of wavelet transforms decomposition of the stator current," Applied power electronics confereces and expositio, 2008.
- [11] J.C. Bezdek, R.Ehrlich, and W.Full, "FCM: The fuzzy c- means clustering algorithm," Computers & Geosciences, 1984.
- [12] J. Cybernet. J.C. Bezdek , "Cluster validity with fuzzy sets,"Computers&Geosciences, 1974.
- [13] Q.Yang, J.Guo, D.Zhang, Ch.Liu , "Fault Diagnosis Based on Fuzzy C-means Algorithm of the Optimal Number of Clusters and Probabilistic Neural Network," International Journal of Intelligent Engineering & Systems , 2011.
- [14] J. Quiroga, Li Liu, and D. A. Cartes "Fuzzy Logic based Fault Detection of PMSM Stator Winding Short under Load Fluctuation using Negative Sequence Analysis,"American Control Conference, 2008.
- [15] K.Tanaka "An Introduction to Fuzzy Logic for Practical Applications," Springer, 1996 edition, 1996 , ISBN-10 : 0387948074.

